

Charging Tests

Start Date/ Time	Finish Date/ Time	Duration (m/h)	Nos Batteries	Batt IDs	Start Voltage (V)	Finish Voltage (V)	dV (V)	Drive Current (A)	RPM after 1m	Comments	Arr. No
01/10/18	01/10/18	3.5m	2	D1,C1	11.64 14.26	11.61 17.91	-0.03 3.65	1.26	1,025	'Generator' mode	1
01/10/18	01/10/18	3.5m	2	D1,C1	11.73 14.16	11.64 14.23	-0.09 0.07	1.19	1,210	'Classic' mode	2
01/10/18	01/10/18	3.5m	3	D1,C1, C2	11.72 13.42 13.09	11.60 13.51 13.24	-0.12 0.09 0.15	1.16	1,145	'Generator' mode with two charging batteries	1
01/10/18	01/10/18	3.5m	3	D1,C1, C2	11.67 13.42 13.16	11.58 13.47 13.25	-0.09 0.05 0.09	1.13	1,175	'Classic' mode with two charging batteries	2
01/10/18	01/10/18	3.5m	4	D1,C1, C2,C3	11.67 13.40 13.71 12.79	11.56 13.46 13.83 12.85	-0.11 0.06 0.12 0.06	1.10	1,150	'Generator' mode with three charging batteries	1
01/10/18	01/10/18	3.5m	4	D1,C1, C2,C3	11.67 13.39 13.75 12.82	11.54 13.44 13.82 12.87	-0.13 0.05 0.07 0.05	1.13	1,138	'Classic' mode with three charging batteries	2

Arrangement 1

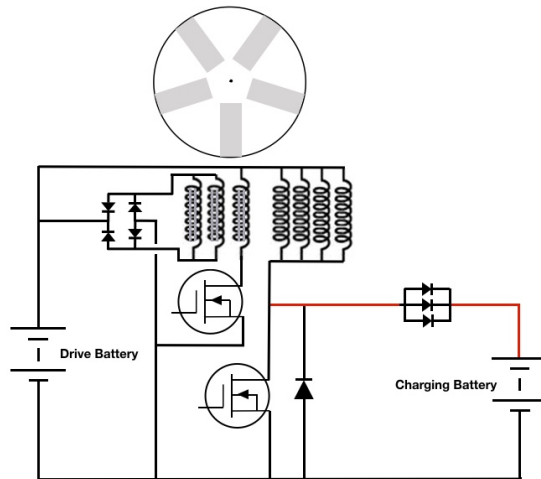

Arrangement 2

